

ALTERNATE SPINDLE
LOCK NUT DESIGNS:

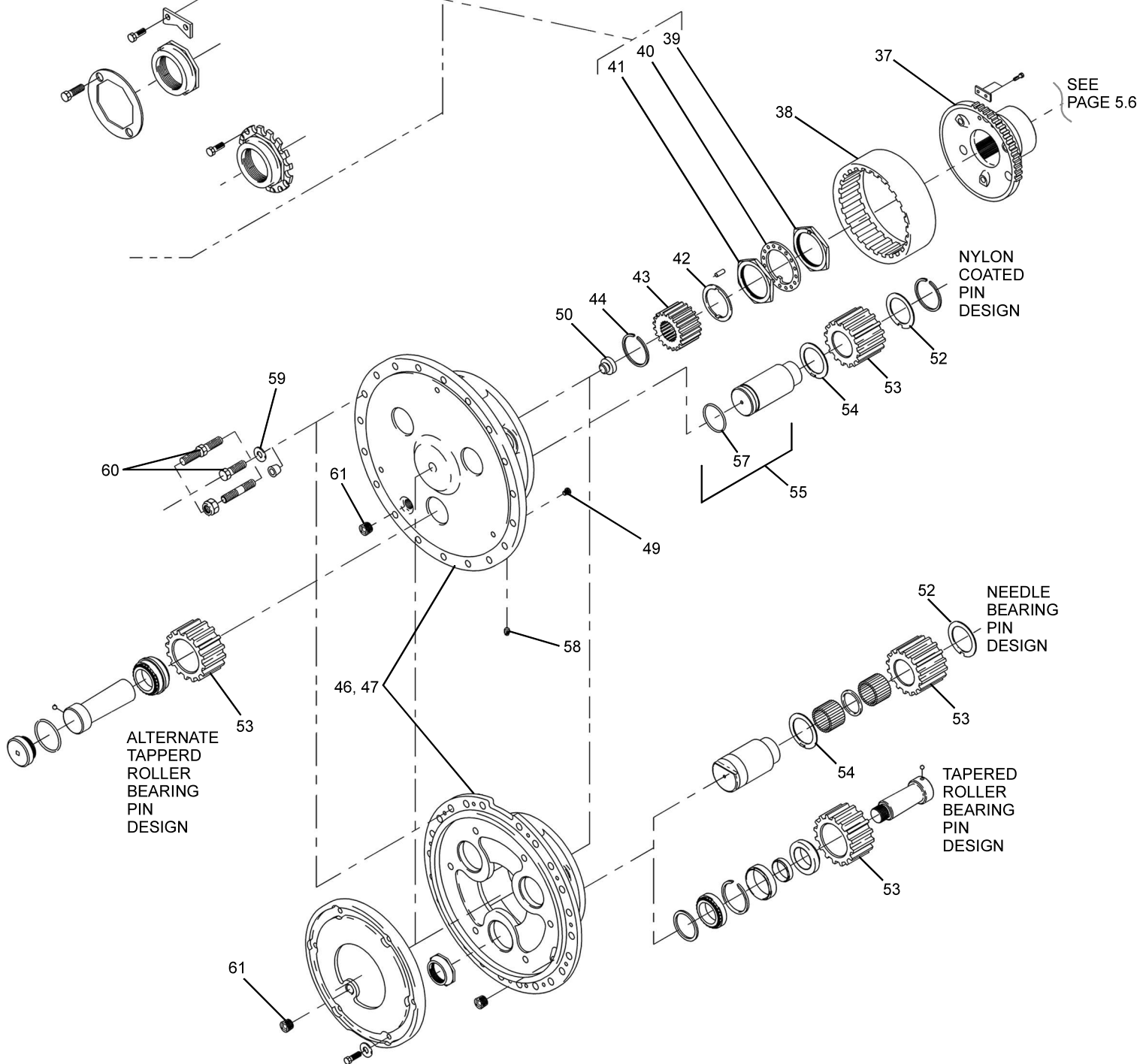
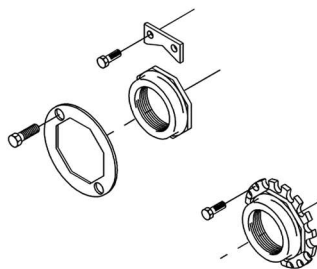

SEE
PAGE 5.6

SEE PAGE 5.8

WHEN ORDERING PARTS, SPECIFY MODEL NUMBER, SERIAL NUMBER AND DESCRIPTION OF PART REQUIRED

TEREX  **CRANES**

HUB & SHAFT GROUP

DATE: Revised 11-2009

MODEL: RT500-1

PAGE 5.6

GROUP

5

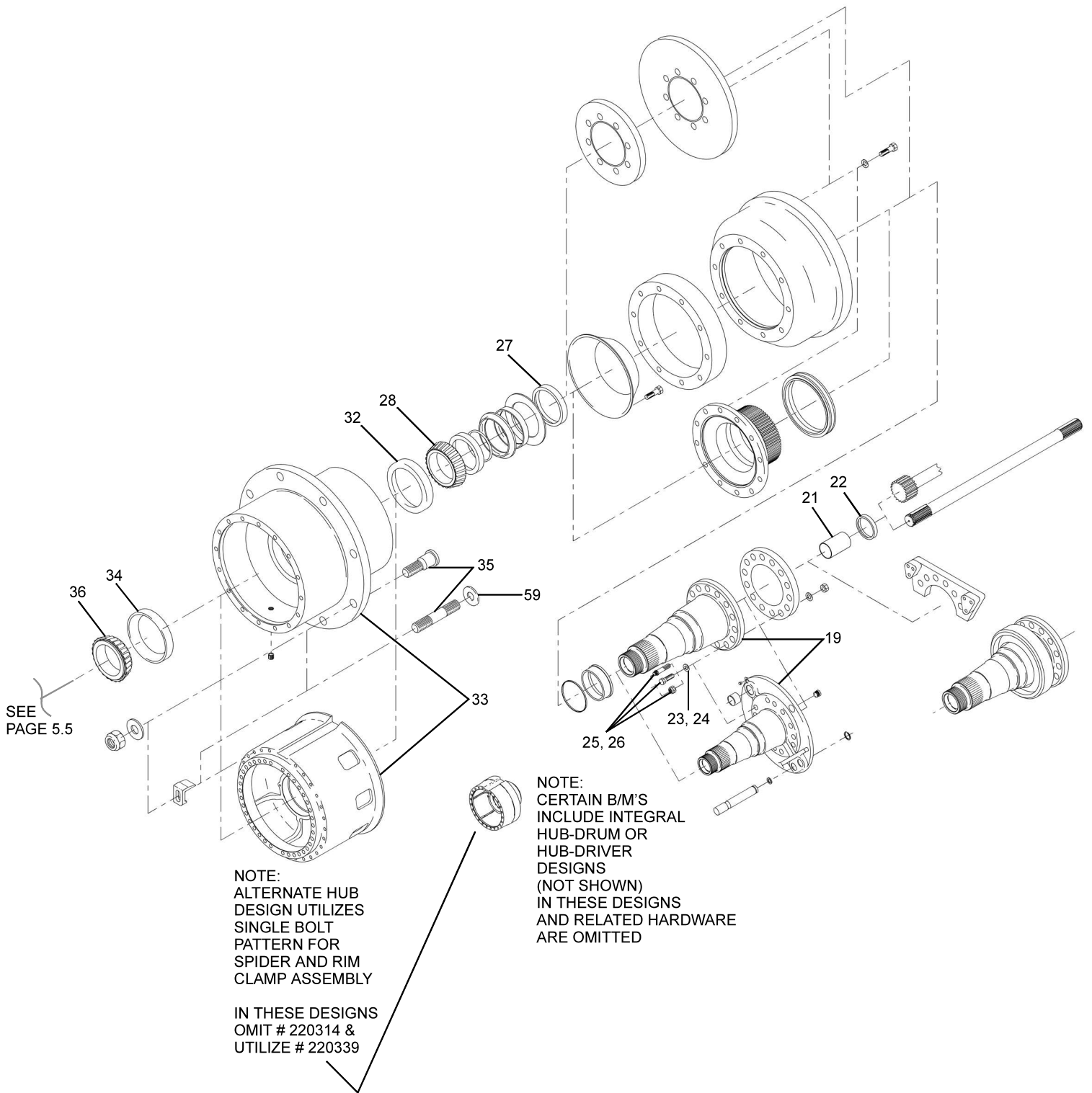

SEE PAGE 5.8

WHEN ORDERING PARTS, SPECIFY MODEL NUMBER, SERIAL NUMBER AND DESCRIPTION OF PART REQUIRED

TEREX  **CRANES**

HUB & SHAFT GROUP

DATE: Revised 11-2009

MODEL: RT500-1

PAGE 5.7

GROUP

5